



Z888-36-HD

SPECIFICATION SHEET

HI-CAP SLOTTED DRAINAGE SYSTEM WITH HEAVY-DUTY
FRAME FOR 36 [914] CORRUGATED PIPE OR EQUIVALENT

TAG _____

Dimensional Data (inches and [mm]) are Subject to Manufacturing Tolerances and Change Without Notice

Specifying engineer is responsible for concrete encasement and reinforcing based upon application and local codes.

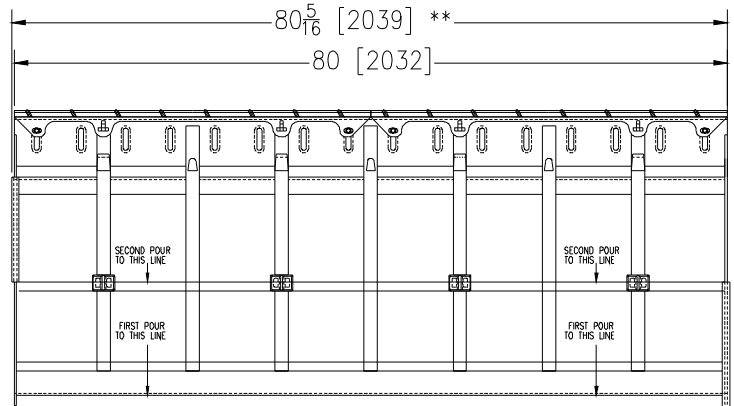
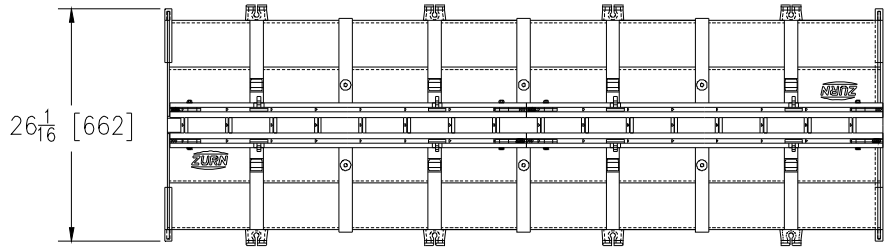
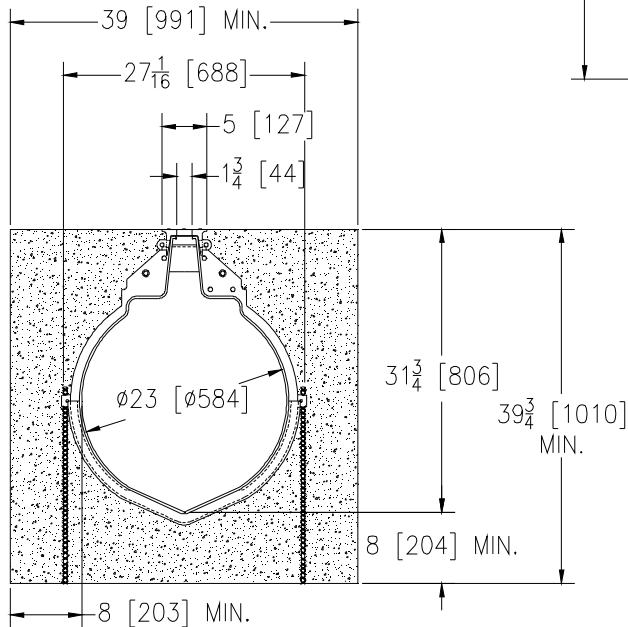

** 80 5/16 [2039] LENGTH INCLUDES MALE/FEMALE JOINT OVERLAP

ENGINEERING SPECIFICATION: Zurn Z888-36-HD

Slotted Drain channel is 80 [2032] long, 31.75 [806] deep invert, 23 [584] wide with a 1.75 [44] throat width, made from HDPE High Density Polyethylene. Channels have a mechanical tongue and groove and bolted connection, mechanically lock into the concrete surround every 5 [127] along its length, channels weigh 10.2 lbs. per foot [15.2 kg per meter]. Channel has a smooth 2.5 [64] radiused bottom with a smooth .011 Manning's coefficient, and neutral non-sloping body. Top reveal is non removable and is the finish at the surface, System is anchored into the concrete with Rebar clips or physical anchors every 5 [127] to 10 [254] along the channel body. Integral Rebar Clips are standard. The Channel has a non-removable ductile Iron Frame/Grate conforming to ASTM A536-84, Grade 80-55-06. Minimum 2000 psi concrete encasement shall include longitudinal #4 0.5 [13] rebar along chairs on either side of the trench neck. System is capable of Supporting Class C Loading per DIN EN1433 top load classifications.

PREFIX OPTIONS

___ Z 80 [2032] High Density Polyethylene Modular Drain Channel with integral Top Frame.*

FRAME OPTIONS

___ -HDG Galvanized Ductile Iron Frame w/ Slot
 ___ -DYN Reinforcing Schedule for Higher Loading

SUFFIX OPTIONS

___ -E1 EndCap
 ___ -E12 12 [305] No Hub End Outlet
 ___ -E18 18 [457] No Hub End Outlet
 ___ -E24 24 [610] No Hub End Outlet
 ___ -E36 36 [914] No-Hub End Outlet
 ___ -T18/36 Transition from -18 to -36 [457-914]

Supplied By:



877-903-7246

www.trenchdrainsupply.com

REV. B DATE: 10/18/12 C.N. NO. 124854

DWG. NO. 64002 PRODUCT NO. Z888-36-HD

*Regularly Furnished Unless Otherwise Specified